

H₂ Ready

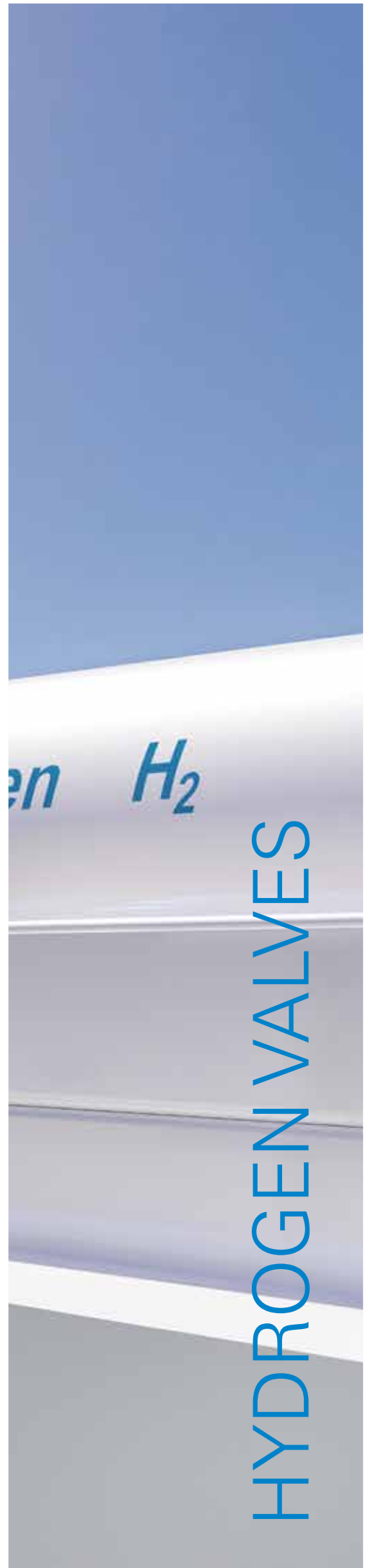

HYDROGEN VALVES



MHA ZENTGRAF
FlowControlTechnology



MHA ZENTGRAF

Your sustainable partner

Sustainability not only needs innovative products but also a sustainable partner. You can rely on **MHA ZENTGRAF** as your reliable supplier to build up a sustainable partnership. What makes **MHA** a sustainable partner?

H₂ Ready

In the future, hydrogen will make a significant contribution to sustainability and environmental protection. For example, in e-mobility as an alternative fuel in fuel cells or in the production of green steel.

With years of experience in the gas sector, **MHA ZENTGRAF** has developed ball valves and flow control solutions for the complete hydrogen process chain: Hydrogen generation, transport and mobile pipelines as well as compression and dispenser stations. Pressure ratings up to 1000 bar are realized.



Environment

- ISO14001 certified
- RoHS und REACH compliant products
- Recyclable packaging material
- Lead free carbon steel
- Raw materials from certified european sources

Our ball valves are used in renewable energy and innovative systems like:

- Wind turbines
- Hydropower plants
- CO₂ extraction systems



Certified quality

- ISO 9001 certified
- DNV/GL type approval
- ABS design assessment
- VdS certified



Digital

- ERP controlled production
- Digitally supported test cert. creation
- EDI-ready for customers



Global

- 4 branch offices worldwide
- Customer support in all time zones



Risk management

- Private owned company
- Manufacturing sites at multiple locations



Innovative

- Supplier for customized solutions
- 15% engineers and scientists



Fast & flexible

- High level of manufacturing depth
- Customized products and processes
- Over 30000 products on stock

MHA valves - Design features ...

... and certified performance



Size reduction

Ball valves have a significant advantage compared to other types of valves:

Full flow cross section in open position! A DN13 1/2" ball valve has a Cv value of 22 gal / min. This Cv value can only be reached with sizes of approx. DN32 (1 1/4") at other valve types, e.g. globe or needle valves. In addition, ball valves can be used to achieve a high degree of leakage free closure.



Temperature range

- Materials suitable for temperatures from -40 °C up to +140 °C
- Temperature range acc. ISO 19880-3 is specified as -40 °C / +85 °C



Leakage

Internal and external leakage acc. DIN EN 12266 leakage rate A and the TPED standard for ball valves, ISO 23826



Lubricants and cleaning

- Oil and grease free products through ultrasonic cleaning
- Assembly of valves without additional lubrication at all wetted surfaces

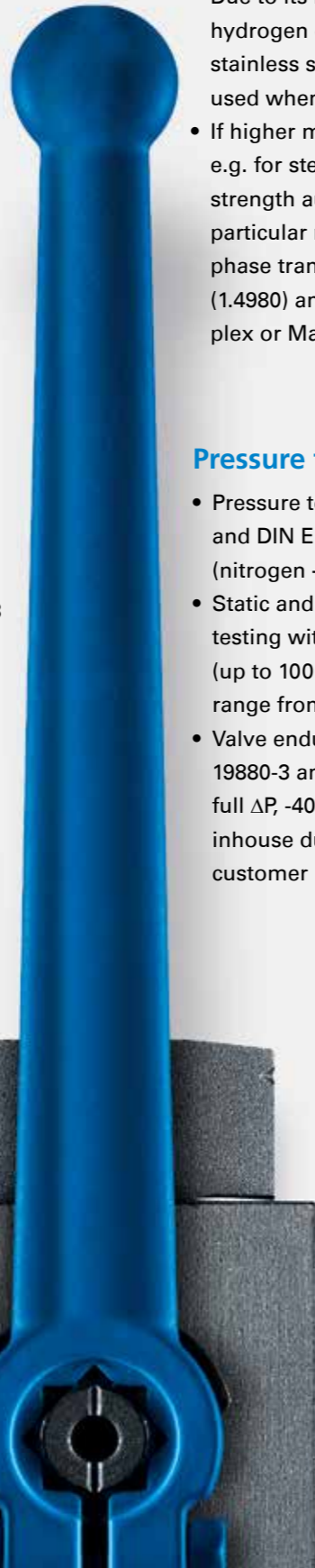

Metallic materials

- Due to its high resistance against hydrogen embrittlement, 316-Series stainless steels (1.4404, 1.4571) are used whenever possible.
- If higher material strength is required, e.g. for stems, balls or trunnions, high strength austenitic stainless steels with particular resistance to strain-induced phase transformations, such as A286 (1.4980) and Nitronic-50®, are used. Duplex or Martensitic grades are avoided.



Pressure testing

- Pressure testing acc. DIN EN 12266-1 and DIN EN 14246 with test gas (nitrogen + helium)
- Static and Cyclic high pressure gas testing with air (≤ 550 bar) or nitrogen (up to 1000 bar) in the temperature range from -40 °C to + 85 °C
- Valve endurance tests acc. to ISO 19880-3 and ISO 23826 (actuation at full ΔP , $-40 \text{ °C} \leq T \leq +85 \text{ °C}$) carried out inhouse during development and on customer request



Sealing materials

- All sealing materials chosen to prevent damages through explosive decompression (e.g. NORSOK M-710)
- Sealing materials acc. DIN EN ISO 11114-2 for hydrogen usage
- Special attention is paid to low temperature seal performance



TPED

Certified by german BAM according DIN EN ISO 23826



Fire-safe

Approved according DIN EN ISO 10497



ATEX

Compliant for category IIC, Ex-zone 1, 2G



Hydrogen embrittlement

All material resistant against hydrogen embrittlement according to ISO 11114-1/2

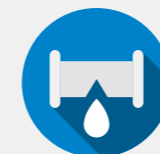

Technical leak tightness

- Readjustable packing
- Internal and external leakage according DIN EN 112266 leakage rate A and the TPED standard for ball valves, ISO 23826



Explosive decompression resistance

All sealing materials chosen to prevent damages through explosive decompression (e.g. NORSOK M-710)

Flow control solutions across the H₂ process chain

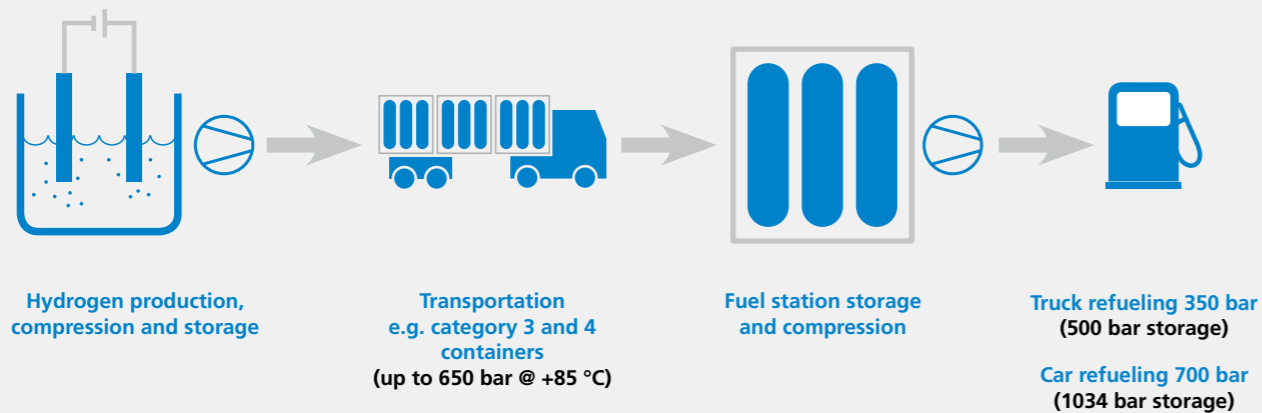

Our products can be used in the complete hydrogen process chain - hydrogen generation, transport and mobile pipelines as well as compression and refueling stations. We also pay attention to your specific application conditions to offer you the technically and economically best solution.

Hydrogen production

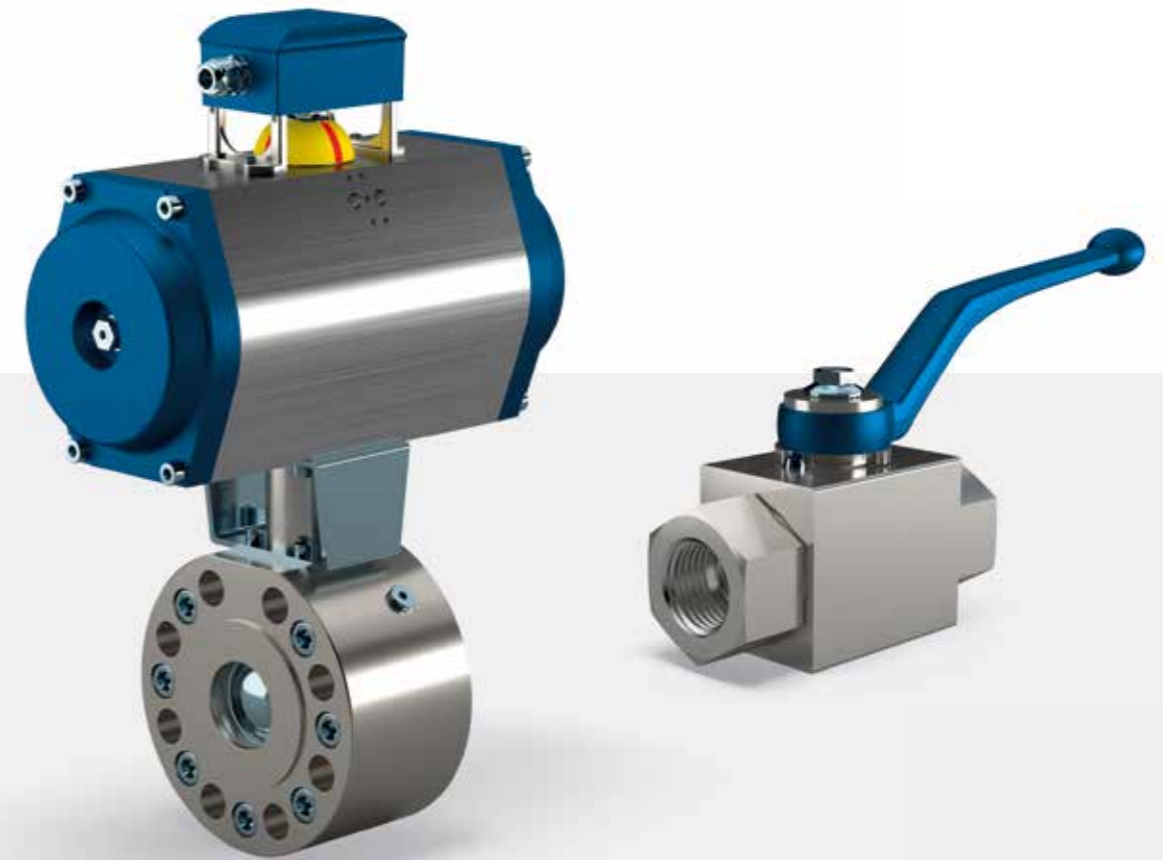
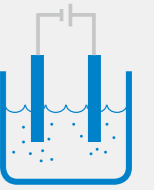

H₂ production

This application includes systems e.g. for electrolysis or power-to-gas systems. Of course, ball valves from **MHA ZENTGRAF** can also be used at these lower pressure applications.

Larger nominal widths of up to 4" can also be offered to ensure maximum flow capacity. A leakage rate A according to DIN EN 12266 is guaranteed even at larger nominal diameters.

Our valves are available with either threaded or flange connection according your specification. On request accessories like limit switches, locking devices or fully automated valves are available.





Transport, storage & refueling systems



HFKH500

Hydrogen applications up to 500 bar

Gas transport and refueling applications set higher requirements for ball valves. At 350 bar refueling, system pressures up to 500 bar occur during compression and storage. Considering the temperature influence, a Type 3 Technology Cylinder for example is designed for system pressures of approximately 480 bar. During transport, vibrations and weather influences can put heavy strain on the system equipment. Additionally, valves for such kind of applications are actuated more frequently because filling and drain processes are carried out regularly.

For use as a maintenance valve, with occasional operations, we recommend our proven ball valves with gas seat system using hydrogen-compatible materials.

For ball valves with higher operation frequencies up to 500 bar, we offer our new HFKH500. Our ball valves are designed for switching under full differential pressure. On request, our ball valves can be supplied as a complete unit with assembled and tested actuator.

These ball valves already meet the endurance requirements of the new ISO 23826 and ATEX IIC (H₂), Ex-zone 1, 2G.

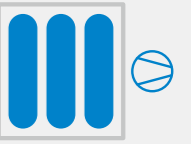

Transport, storage & refueling systems

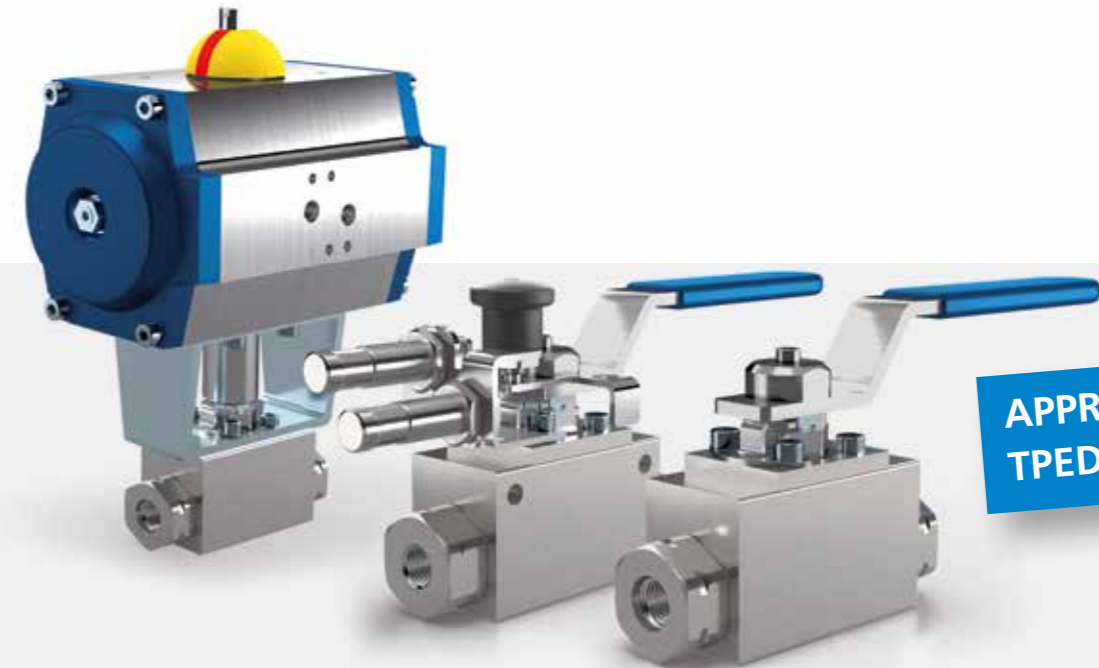

APPROVED:
TPED, Fire-safe, ATEX

HFKH650

Hydrogen applications up to 650 bar

Higher compression of hydrogen during transport and storage improves the efficiency of the systems, saves installation space and, last but not least, reduces costs. Considering the temperature influence, State of the Art Type 4 Technology Cylinders are designed for pressures up to 650 bar.

With the new HFKH650 ball valve, **MHA** offers a reliable solution for this kind of application. Additionally, it has a torque-optimized design so it can be conveniently switched by hand even at full differential pressure.

The new ball valve series already meets the endurance requirements of the new ISO 23826 standard. In addition our ball valve is certified to the following standards: TPED DIN EN ISO 23826, ATEX IIC (H₂) Ex-zone 1, 2G and Fire-safe DIN EN ISO 10497.





Hydrogen dispenser stations

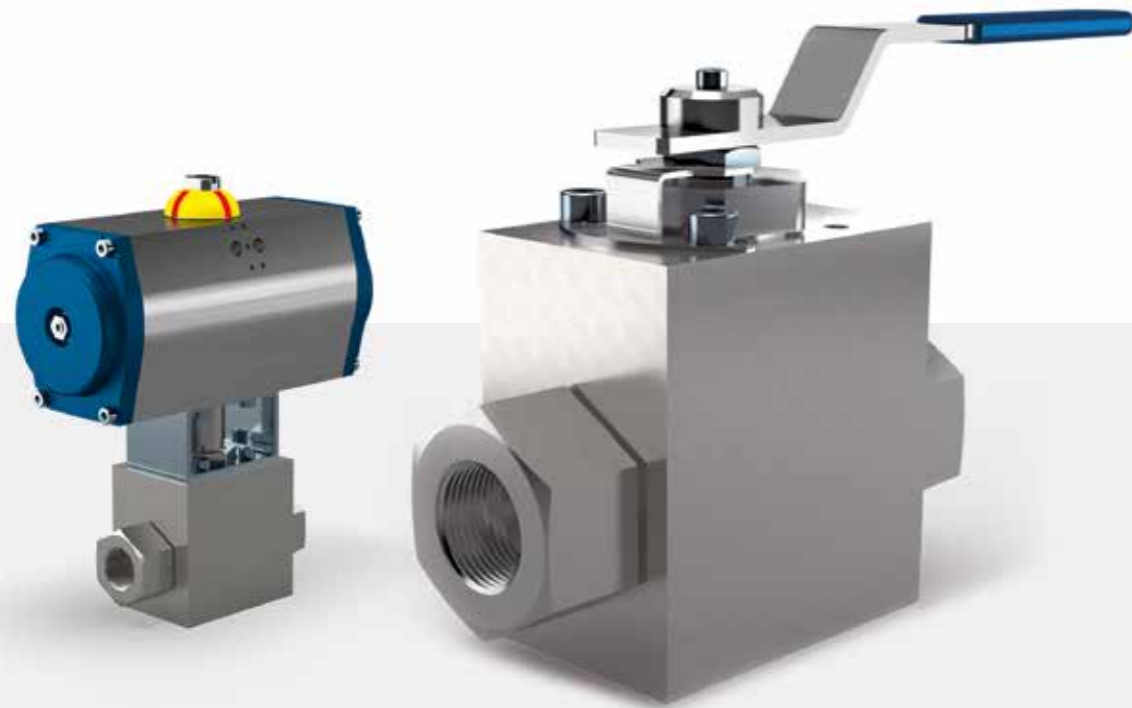

Check valves for hydrogen transport, storage & refueling



HFKH1000

H₂ refueling at pressures up to 1034 bar

At 700 bar refueling of passenger cars, hydrogen is compressed and stored at pressures up to 1034 bar. Latest developments reveal a tendency to 700 bar technology also for commercial vehicles such as trucks and busses.

ISO 19880-3 Standard (Gaseous Hydrogen – Refueling Stations – Part 3: Valves) differs between valves for maintenance (Class B) and operation (Class A) purpose. While Class B Valves are only meant to withstand 100 cycles of operation at room temperature, Class A Valves shall withstand 102000 cycles (100000 at RT, 1000 at -40 °C and another 1000 at +85 °C) without losing integrity of the seal system. **MHA** aims to qualify its HFKH1000 valve acc. to ISO 19880-3, Class A.

To enable up to 102000 actuations under full differential pressure, the HFKH1000 trunnion valve was designed with special attention to reduced wear and friction. This ensures a maximal level of reliability and sustainability even under harshest conditions. This ball valve can be used for ATEX-relevant applications as it is approved for ATEX IIC (H₂) Ex-zone 1, 2G.

RVH2

H₂ transport, storage and refueling up to 1034 bar

Hydrogen transport, storage and refueling applications set high requirements for check valves. At 700 bar refueling of passenger cars, hydrogen is compressed and stored at pressures up to 1000 bar and temperatures as low as -40°C. Latest developments reveal a tendency to 700 bar technology also for commercial vehicles such as trucks and busses.

The check valve RVH2 is specifically designed to fulfil all requirements for hydrogen applications. We offer different cracking pressures to customize the best possible product for your application.

The new check valve series already meets the endurance requirements of the new ISO 23826 and ATEX IIC (H₂), Ex-zone 1, 2G.



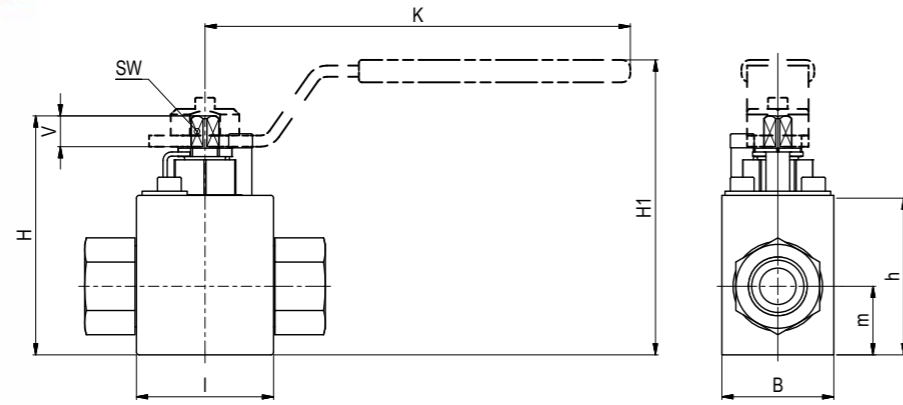

AVAILABLE SIZES

DN8 (3/8"), DN13 (1/2"), DN25 (1")

CONNECTIONS

DIN ISO 228 Female thread, ANSI B1.20.1 NPT Female thread, SAE J514/ISO/DIS11926-1 Female thread, DIN 2353 / ISO 8343-1 Heavy series, others on request

ACCESSORIES ON REQUEST

- Locking devices
- Actuators
- Mounting holes
- Position switches
- Combinations
- Detent

MATERIAL CODE DESCRIPTION

Materials	44g8
Body	1.4571
Ball	1.4571 / Nitronic-50®
Stem	Nitronic-50®
Ball seats	PEEK
Body and stem sealing	FKM / PTFE*
Tmin / Tmax	-40°C / +85°C*

*Others on request.

CERTIFICATION

ATEX IIC (H2), Ex-zone 1, 2G

GENERAL DIMENSIONS

Type	I	B	H	h	m	Vmin	SW	K	H1	Lever
HFKH500-DN8	42	38	74,5	46	16,5	11	8	152	94,5	St
HFKH500-DN13	49	40	85,5	57	24,5	11	8	152	105,5	St
HFKH500-DN25	83,5	70	124	93	35	13,5	12	202	146,5	St

CONNECTION TYPE	DIMENSIONS							ORDER CODE PER MATERIAL COMBINATION		
DIN ISO 228 FEMALE THREAD	Type	LW	L	i	d	Weight [Kg]	PN [bar]	44g8		
	HFKH500-DN8-G 1/4	8	69,6	14	G 1/4	0,67	500	on request		
	HFKH500-DN13-G 1/2	13	86	16,3	G 1/2	1,15	500	on request		
	HFKH500-DN25-G 1	25	130,7	20	G 1	5,16	500	on request		
ANSI B1.20.1 NPT FEMALE THREAD	Type	LW	L	i	d	Weight [Kg]	PN [bar]	44g8		
	HFKH500-DN8-1/4" NPT	8	71,6	13,7	1/4" NPT	0,67	500	on request		
	HFKH500-DN13-1/2" NPT	13	86	17	1/2" NPT	1,16	500	on request		
	HFKH500-DN25-1" NPT	25	130,7	21,6	1" NPT	5,18	500	on request		
SAE J514/ISO/DIS11926-1 FEMALE THREAD	Type	LW	L	i	d	Weight [Kg]	PN [bar]	44g8		
	HFKH500-DN8-9/16" UNF	8	75,6	13	9/16"-18 UNF	0,73	500	on request		
	HFKH500-DN13-3/4" UNF	13	86	15	3/4"-16 UNF	1,16	500	on request		
	HFKH500-DN25-1 5/16" UN	25	130,7	20	1 5/16"-12 UN	5,13	500	on request		
DIN 2353 / ISO 8343-1 HEAVY SERIES	Type	LW	RA	L	i	d	Weight [Kg]	PN [bar]	44g8	
	HFKH500-DN8-12S	8	12	78,6	7,5	M 20x1,5	0,67	500	on request	
	HFKH500-DN13-16S	13	16	89,6	8,5	M 30x2	1,12	500	on request	
	HFKH500-DN25-30S	25	30	137,9	13,5	M 42x2	4,77	500	on request	

Please note the pressure ratings of the tube connections!

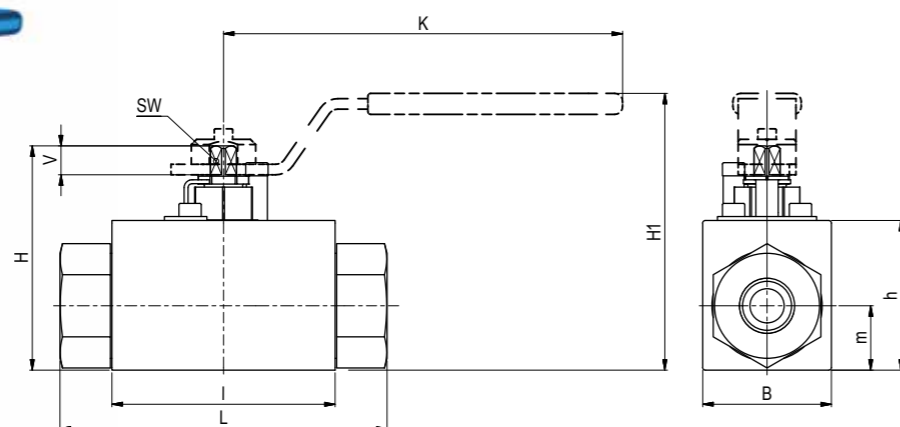

AVAILABLE SIZES

DN8 (3/8"), DN13 (1/2"), DN25 (1")

CONNECTIONS

DIN ISO 228 Female thread, ANSI B1.20.1 NPT Female thread, SAE J514/ISO/DIS11926-1 Female thread, DIN 2353 / ISO 8343-1 Heavy series, C&T medium Pressure, others on request

ACCESSORIES ON REQUEST

- Locking devices
- Actuators
- Mounting holes
- Position switches
- Combinations
- Detent

MATERIAL CODE DESCRIPTION

Materials	44g8
Body	1.4571
Ball	1.4571 / Nitronic-50®
Stem	Nitronic-50®
Ball seats	PEEK
Body and stem sealing	FKM / PTFE*
Tmin /Tmax	-40°C / +85°C*

*Others on request.

CERTIFICATION

- ATEX IIC (H2), Ex-zone 1, 2G
- Fire-safe DIN EN ISO 10497
- TPED DIN EN ISO 23826

GENERAL DIMENSIONS

Type	L	B	H	h	m	Vmin	SW	K	H1	Lever
HFKH650-DN8	75,5	38	74,5	46	16,5	11	8	152	94,5	St
HFKH650-DN13	85	49	85,5	57	24,5	11	8	152	105,5	St
HFKH650-DN25	120	78	128,5	97	39	13,5	12	202	151,1	St

CONNECTION TYPE	DIMENSIONS							ORDER CODE PER MATERIAL COMBINATION			
DIN ISO 228 FEMALE THREAD	Type	LW	L	i	d	Weight [Kg]	PN [bar]	44g8			
	HFKH650-DN8-G 1/4	8	105,1	14	G 1/4	1,34	650	on request			
	HFKH650-DN13-G 1/2	13	124,6	16,3	G 1/2	2,35	650	on request			
	HFKH650-DN25-G 1	25	159,6	20	G 1	7,83	650	on request			
ANSI B1.20.1 NPT FEMALE THREAD	Type	LW	L	i	d	Weight [Kg]	PN [bar]	44g8			
	HFKH650-DN8-1/4" NPT	8	105,1	13,7	1/4" NPT	1,34	650	on request			
	HFKH650-DN13-1/2" NPT	13	124,6	17	1/2" NPT	2,36	650	on request			
	HFKH650-DN25-1" NPT	25	159,6	21,6	1" NPT	7,85	650	on request			
SAE J514/ISO/DIS11926-1 FEMALE THREAD	Type	LW	L	i	d	Weight [Kg]	PN [bar]	44g8			
	HFKH650-DN8-9/16" UNF	8	105,1	13	9/16"-18 UNF	1,33	650	on request			
	HFKH650-DN13-3/4" UNF	13	124,6	15	3/4"-16 UNF	2,36	650	on request			
	HFKH650-DN25-1 5/16" UN	25	159,6	20	1 5/16"-12 UN	7,81	650	on request			
DIN 2353 / ISO 8343-1 HEAVY SERIES	Type	LW	RA	L	i	d	Weight [Kg]	PN [bar]	44g8		
	HFKH650-DN8-12S	8	12	113,1	7,5	M 20x1,5	1,29	650	on request		
	HFKH650-DN13-16S	13	16	128,6	8,5	M 30x2	2,19	650	on request		
	HFKH650-DN25-30S	25	30	179,6	13,5	M 42x2	7,71	650	on request		
C&T MEDIUM PRESSURE	Type	LW	L	i	d	d1	d2	l	Weight [Kg]	PN [bar]	44g8
	HFKH650-DN8-9/16" C&T	8	121,1	11,2	13/16-16UN	12,7	7,8	19,1	1,37	650	on request
	HFKH650-DN13-1" C&T	13	164,6	20,6	1 3/8-12UNF	22,4	14,3	33,3	2,65	650	on request
	HFKH650-DN25-1 1/2" C&T	25	219,6	25,4	1 7/8-12UNF	35	23,8	40,5	9,30	650	on request

Please note the pressure ratings of the tube connections!

Block ball valve Stainless Steel

HFKH1000

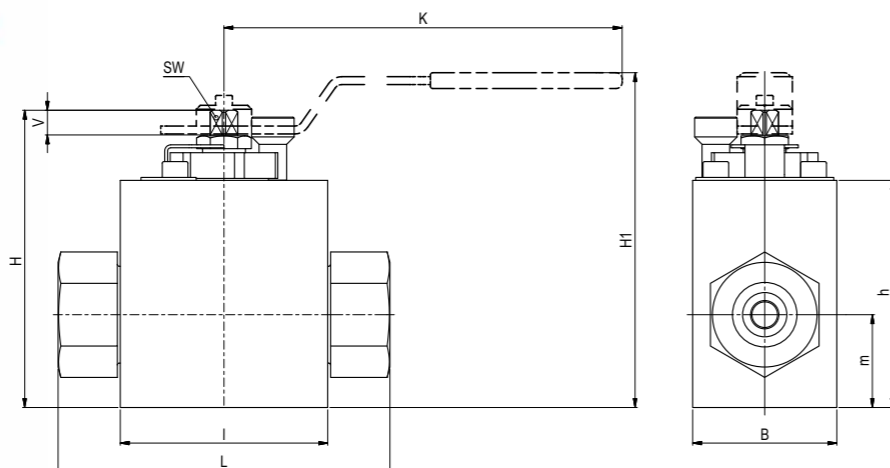

AVAILABLE SIZES

DN8 (3/8"), DN13 (1/2")

CONNECTIONS

C&T medium Pressure, others on request

ACCESSORIES ON REQUEST

- Locking devices
- Actuators
- Mounting holes
- Position switches
- Combinations
- Detent

MATERIAL CODE DESCRIPTION

Materials	44m8
Body	1.4571
Trunnion	Nitronic-50®
Ball seats	PEEK
Body and stem sealing	FKM / PTFE*
Tmin / Tmax	-40°C / +85°C*

*Others on request.

CERTIFICATION

ATEX IIC (H2), Ex-zone 1, 2G

GENERAL DIMENSIONS

Type	I	B	H	h	m	Vmin	SW	K	H1	Lever
HFKH1000-DN8	88	65	148	110	45	12,5	9	202	167	St
HFKH1000-DN13	105	73	150,5	115	47	12,5	11	202	169,5	St

CONNECTION TYPE

DIMENSIONS

ORDER CODE PER MATERIAL COMBINATION

C&T MEDIUM PRESSURE

Type	LW	L	i	d	d1	d2	l	Weight [Kg]
HFKH1000-DN8-9/16" C&T	8	131	11,2	13/16-16UN	7,8	12,7	19,1	6,08
HFKH1000-DN13-1" C&T	13	168	20,6	1 3/8-12UNF	14,3	22,4	33,3	8,37

PN [bar]	44m8
1034	on request
1034	on request

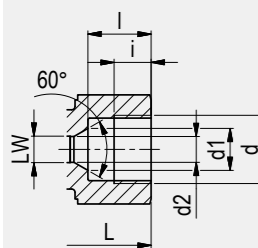

Please note the pressure ratings of the tube connections!

Check valve Stainless Steel

RVH2



PORTING PATTERN

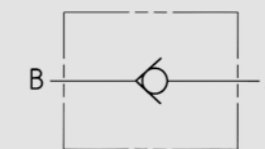

CERTIFICATION

ATEX IIC (H2), Ex-zone 1, 2G

CONNECTIONS

DIN ISO 228 Female thread, ANSI B1.20.1 NPT Female thread, SAE J514/ISO/DIS11926-1 Female thread, DIN 2353 / ISO 8343-1 Heavy series, C&T medium Pressure, others on request

AVAILABLE SIZES

DN8 (3/8"), DN13 (1/2")

MATERIAL

Body	1.4571
Seats	PEEK
Tmin / Tmax	-40°C / +85°C
Cracking pressure	as required

PRESSURE RATING

PN 1034 bar

Ball valve accessories



HFKH500, HFKH650 and HFKH1000

Wide range of accessories available

- Actuators – pneumatic, electric, hydraulic
- Position indicators
- Mounting holes
- Locking devices
- Detents
- Manifold integration





The right product for your hydrogen application

500 BAR

650 BAR

1034 BAR

1034 BAR



HFKH500

- DN8 (3/8"), DN13 (1/2"), DN25 (1")
- Floating ball
- PN: 500 bar
- ATEX

HFKH650

- DN8 (3/8")*, DN13 (1/2"), DN25 (1")
- Floating ball
- PN: 650 bar
- ATEX, Fire-safe, *TPED

HFKH1000

- DN8 (3/8"), DN13 (1/2")
- Trunnion ball
- PN: 1034 bar
- ATEX

RVH2

- DN8 (3/8"), DN13 (1/2")
- Check valve
- PN: 1034 bar
- ATEX

